

# Capital-City Cricket League



## *Table of Contents*

<b>REVISION CONTROL .....</b>	<b>3</b>
<b>ABOUT CCL.....</b>	<b>5</b>
<b>1 GROUPING AND FORMAT .....</b>	<b>7</b>
<b>2 FIELD.....</b>	<b>13</b>
<b>3 RESULTS.....</b>	<b>14</b>
<b>4 MATCH REGULATIONS – BASIC RULES .....</b>	<b>16</b>
<b>5 SCORING .....</b>	<b>20</b>
<b>6 ETHICS AND EXPECTATIONS .....</b>	<b>21</b>
<b>7 TEAMS.....</b>	<b>22</b>
<b>8 PLAYERS .....</b>	<b>23</b>
<b>9 PLAYERS’ CODE OF CONDUCT .....</b>	<b>25</b>
<b>10 APPLICATION AND ENFORCEMENT OF THE CODE:.....</b>	<b>26</b>
<b>11 UMPIRES.....</b>	<b>27</b>
<b>12 DELAYS OR INTERRUPTIONS.....</b>	<b>29</b>
<b>13 PENALTY .....</b>	<b>30</b>
<b>14 AWARDS .....</b>	<b>32</b>
<b>15 APPENDIX-A .....</b>	<b>34</b>
<b>16 APPENDIX-B .....</b>	<b>35</b>

## **Revision Control**

<b>Section Updated</b>	<b>Date</b>	<b>Update Description</b>	<b>Updated by**</b>
Most of the sections updated (1.1, 1.2, 1.3, 2.3, 8.5,8.9, 9.10, 10.4, 11.12)	02/29/2024	Initial set of changes for 2024, Grouping, Team Qualification scenarios, Player Qualification, Uniform Requirement, Code of Conduct, Umpire responsibility	Mayuresh Varerkar
Most of the sections updated (1.1, 4.4.3,4.4.10,4.4.11, 8.4,8.5,13.9)	02/15/2023	Initial set of changes for 2023, Grouping, DRC, Rule changes- No ball, Playoff qualification, No crossing on fall of wicket, etc.	Mayuresh Varerkar
Most of the sections updated	02/19/2022	Initial set of changes for 2022, Grouping, etc	Mayuresh Varerkar
Most of the sections updated	03/25/2021	Initial set of changes for 2021, Grouping, etc	Mayuresh Varerkar
Most of the sections updated	02/27/2020	Initial set of changes for 2020, Grouping, Format-20 over, delays and interruptions	Mayuresh Varerkar
Most of the sections updated	03/11/2019	Initial set of changes for 2019, Grouping, Format, delays and interruptions	Mayuresh Varerkar
1.2, 1.3, Board Chair, CRC	07/29/2018	Updated playoff format for 2018 season for Div A and B	Mayuresh Varerkar
1.1,1.2,1.3,2.2,5.1, 13.6, Other sections specific to 2017	3/10/2018	Changed all sections from 2017 to 2018 specific information, Modified format, groupings for 2018, Added penalty for ground violation	Mayuresh Varerkar
1.3, 1.4, 3, 4.13, 13, 14	5/24/2017	Updated late show, points, penalty points, awards and playoff format and qualification	Mayuresh Varerkar
Umpiring and Penalty Sections	3/10/2017	Umpire responsibility and penalty rules for late start	Mayuresh Varerkar
All Sections	3/7/2017	Uniforms, walkovers, and other related rules for CCL 2017	Mayuresh Varerkar
Most of the sections updated	2/10/2017	CCL Groups 2017	Mayuresh Varerkar

Most of the sections updated	1/8/2017	Initial set of changes for CCL 2017	Sanket Dave
12.4	4/6/2016	Section 12.4 is consistent with section 5.10	Sanket Dave
3.6/3.7	4/3/2016	Updated the NRR to match with ICC rules	Pranav Bhatt
About CCL, Format, rescheduling info, most of the sections were updated for CCL 2016.	03/14/2016	Updated for CCL 2016. Mainly the format and about CCL section, learnings from last year.  Some more update will be made before the tournament starts.	Bhavin/Pranav
1.1.18 / Section 13 added	06/18/2014	Added Division B and awards information	Bhavin
Most of the sections were updated	03/12/2014	Document updated with the changes for CCL 2014	Bhavin
Appendix-A	03/14/2013	Updated ground/pitch dimensions	Urvin Modi
4.4.2.4 Appendix-C	03/12/2013	Updated Sections for Pitch/360 Ground Roles of CCL members(Appendix C)	Pranav Bhatt
4.4.11.1	04/05/2012	Document creation	Urvin Modi
4.4.12	04/05/2012		Urvin Modi
4.4.2.1 / 4.4.2.2 / 4.4.2.3	04/05/2012		Urvin Modi
Appendix-A	04/05/2012		Urvin Modi

**\*\* - Any rule will be updated or changed only after approval of at least 4 committee member.**

---

## **About CCL**

### ***CCL - "Capital City Cricket League" (previously known as FCL, Folsom cricket league)***

CCL is a brainchild of bunch of friends, happened to be cricket fans. In all those years, CCL has successfully completed many seasons. What we all like about CCL is it provides solid platform for fun cricket with enough competitiveness. We have 500+ players registered and played in CCL, and still counting. All of this is only possible with everyone's support and excitement for the game of Cricket. Looking forward to same support from all teams and players to improve our standards step by step, at the end it's all for the game we all love and cherish – CRICKET

Our mission and intention are to provide safe, quality, competitive and organized recreational cricket.

We have bodies in CCL who contributes to conducting CCL in the most efficient way.

#### **What is a Board?**

Body consisting of a single representative for a team (Captain or manager) that has registered to play CCL for that season.

#### **Board responsibilities**

- Ensure all teams comply with CCL regulations.
- Cricketing related decisions
- Dispute Resolution regulations
- On ground conflicts and penalties

#### **What is a CCL Committee?**

Body consisting of some founding members and passionate volunteers responsible for specific tasks.

#### **CCL Committee responsibilities**

1. Ground Reservations, Insurance
2. Collect Funds, Track Finances
3. Update Rules doc if necessary
4. Website Maintenance
5. Order Awards
6. Awards Ceremony logistics

- 
7. CCL Communications
  8. Purchase of balls / Distribution
  9. Ground/pitch maintenance
  10. Porta-potty ordering
  11. Own and Publish Finances
  12. Tournament Scheduling
  13. Publish Weekly Points Table
  14. Weekly Snapshot of player stats and points tables
  15. Tournament Logistics (Start Date, Ceremony Date, etc)
  16. Tournament Structure

Board cannot interfere with the organization and structure of CCL.

**Official CCL Communications will ONLY come from the [ccl\\_committee@googlegroups.com](mailto:ccl_committee@googlegroups.com)**

**Board related discussions will ONLY happen using [ccl\\_cricket\\_board@googlegroups.com](mailto:ccl_cricket_board@googlegroups.com)**

#### **Conflict Resolution Committee and their roles and responsibility:**

CONFLICT RESOLUTION COMMITTEE (CRC) will be handled by an elected panel of 5 members during CCL 2023 reps meeting.

1. Monitor CCL Board Google group email for Issue Resolution Request (IRR) being filed.
2. Resolve all IRR's (**CRC 2023 Roster: Sashi Kiran (Aces), Sabarish Parameswaran (Folsom Scorchers), Bhavin Gandhi (Super 30), Uday Nimmagadda (Top Guns), Prashant Joshi (Twin City Cricket Club)**)
  - a. If a CRC member is part of the team filing for an IRR then the CRC member will not take part in the resolution.
  - b. CRC issues to be resolved by simple majority within CRC.
  - c. If there is a tie within CRC Committee, committee members would resolve the tie by casting their vote. No member whose team is involved in the dispute would take part in the resolution.
  - d. CRC needs to abide and resolve matters **STRICTLY BASED** on the CCL Rules and Bylaws. **NO EXCEPTIONS**

# 1 Grouping and Format

## 1.1 Team Ranking from CCL 2023 and Grouping for 2024

Rank	Team Name	Groups
1	Team Warriors	A
2	GCC	B
3	Top Guns	C
4	Vintage Cricket Club	D
5	EDH Gladiators	D
6	Super 30	C
7	Team Fearless	B
8	Kalinga Warriors	A
9	Folsom Scorchers	A
10	Rebels	B
11	Trojans	C
12	Titans	D
13	Aryans	D
14	United 11	C
15	Folsom Eagles	B
16	Natomas Steelers	A
17	Spartans	A
18	Twin City Cricket Club	B
19	Rajni Gajni	C
20	Aimers	D
21	Aces	D
22	Jaguars	C
23	EDH All Stars	B
24	Deccan Chargers	A
25	Rancho Rowdies	A
26	Royal Strikers	B
27	Royal Blues	C
28	Sargam Super Kings	D

Based on the above ranking for CCL 2023 below is the Grouping for CCL 2024.

<b>Group A</b>		<b>Group B</b>	
1	Team Warriors	2	GCC
8	Kalinga Warriors	7	Team Fearless
9	Folsom Scorchers	10	Rebels
16	Natomas Steelers	15	Folsom Eagles
17	Spartans	18	Twin City CC
-	Deccan Chargers	-	EDH All Stars
-	Rancho Rowdies	-	Royal Strikers

<b>Group C</b>		<b>Group D</b>	
3	TopGuns	4	Vintage CC
6	Super 30	5	EDH Gladiators
11	Trojans	12	Titans
14	United 11	13	Aryans
19	Rajni Gajni	20	Aimers
-	Jaguars	21	Aces
-	Royal Blues	-	Sargam Super Kings



## 1.2 Format for CCL 2024

- **Round 1**

- Group Stage (Round Robin - 6 games per team against all other teams in their group)

Group A	Group B	Group C	Group D
Team A1	Team B1	Team C1	Team D1
Team A2	Team B2	Team C2	Team D2
Team A3	Team B3	Team C3	Team D3
Team A4	Team B4	Team C4	Team D4
Team A5	Team B5	Team C5	Team D5
Team A6	Team B6	Team C6	Team D6
Team A7	Team B7	Team C7	Team D7

- Qualification to Round 2:
  - Top 3 teams from each group qualify to Division A
  - 2 Wild card teams picked amongst 4<sup>th</sup> position teams in each group based on Points and NRR
  - Remaining 14 teams qualify to Division B
  - Points/NRR against other qualifying teams DO **NOT** carry forward; penalty re-sets (Update in 2024)

- **Round 2**

- Groups with 4 qualifying teams in Round 1 will be split in different groups in Round2 (AB, CD OR AC, BD)
- Each Team plays 7 games against all other teams in opposing group of same division.

Div A Group 1	Div A Group 2	Div B Group 1	Div B Group 2
Team A1	Team C1	Team A5	Team C5
Team A2	Team C2	Team A6	Team C6
Team A3	Team C3	Team A7	Team C7
Team A4	Team C4	Team B4	Team D4
Team B1	Team D1	Team B5	Team D5
Team B2	Team D2	Team B6	Team D6
Team B3	Team D3	Team B7	Team D7

- Qualification for Playoffs (TBD)
  - Option1:
    - Each division would have a single points table and each team will play against 7 teams in opposite groups in same division
    - Top 8 teams based on points and NRR in Round 2 qualify for playoffs
    - Top team would be awarded the league championship
  - Option 2:
    - Each division would maintain one points table per group (2 per division) and each team will play against 7 teams in opposite group in same division
    - Top 4 teams from each group based on points and NRR in Round 2 qualify for playoffs
    - Top teams from each group would play a game and the winner would be declared league champion
- Min Games per team (excluding playoffs): 13

### 1.3 Playoff Format (TBD)

- Option 1:

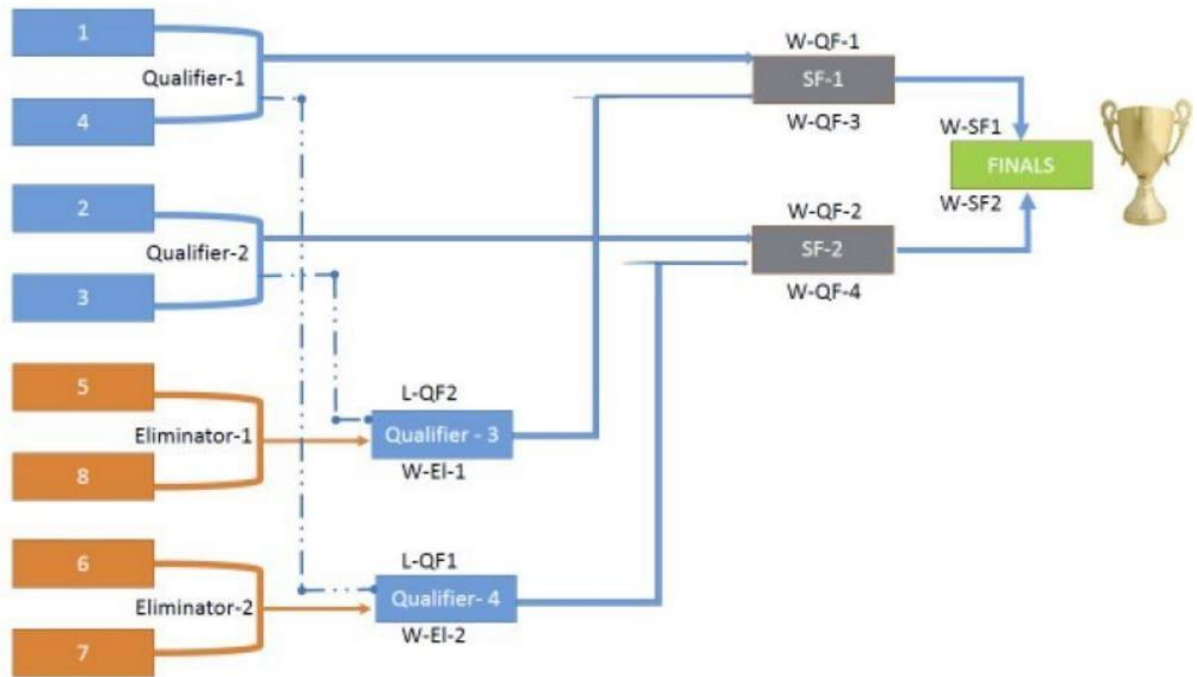

**Division A & B Playoff**

- Option 2:

Week	Game Type	Opponents	# Games
1	Div A- League Championship + Div B Quarter Final	<b>LeagueChamp= DAG1 1vs DAG2 1</b> WBQF1 = DBG1 1vs DBG2 4 WBQF3 = DBG1 2vs DBG2 3 WBQF4 = DBG1 3vs DBG2 2 WBQF2 = DBG1 4vs DBG2 1	1 + 4
2	Div A Quarter Final	WAQF1 = DAG1 1vs DAG2 4 WAQF3 = DAG1 2vs DAG2 3 WAQF4= DAG1 3vs DAG2 2 WAQF2 = DAG1 4vs DAG2 1	4
3	Semi Final	WASF1 = WAQF1 vs WAQF4 WASF2 = WAQF2 vs WAQF3 WBSF1 = WBQF1 vs WBQF4 WBSF2 = WBQF2 vs WBQF3	2 + 2
4	Final	<b>Div A Winner = WASF1 vs WASF2</b> <b>Div B Winner = WBSF1 vs WBSF2</b>	1 + 1

**1.4 Team Qualification Scenario for next round**

If there is a Tie in number of points while deciding which team should go further, team with better NRR shall advance.

1.4.1 In case of NRR tied up to 3 decimal points, head-to-head result will be considered.

1.4.2 In case head- to-head result is not available, total number of wins against all qualifying teams in same division would be considered.

1.4.3 If NRR is tied, head-to-head results not available and total number of wins against all qualifying teams will be equal, both teams shall play a cricket game to break the tie. Schedule cannot be pushed out due to the game. Hence, committee would be deciding on the format of this game.

---

## 2 Field

- 2.1 All CCL games will be played on the field(s) communicated to the team by CCL Committee. CCL will use its Home Ground at [10700 ambassador drive, Rancho Cordova, CA](#) for all the matches.
- 2.2 CCL Teams are not allowed to practice on the CCL Ground without reservation. Penalty will be awarded to the players/ teams if they are found guilty with evidence for using CCL pitches.
- 2.3 "Home team" (team stated first in the schedule fixture on cricclubs website) is responsible for ground setup and is expected to measure the boundary during initial setup. Umpire holds the right to request the home team to measure the boundary if marked without measurement. Cone to Cone is considered as Straight line.
- 2.4 Both the teams are responsible to get one set of spring loaded stumps and cones, No digging in ground and pitch is allowed.
- 2.5 **Both Home and Away teams are responsible for cleaning up** (bottles/wrappers/food etc) from ground as well as dug-outs.
- 2.6 Umpires are required to check the creases, wickets and other required implementation of the game before the toss for innings. If the umpires find even one of the creases either not marked, or improperly marked, or the wickets improperly pitched, the Umpire must request the Home team to resolve such issues before the start of the match.
- 2.7 As guideline to the umpires for the calling of wide on the offside, two off-sides "wide-marker lines" will be drawn perpendicular to the Bowling crease, towards the Popping crease, 3.5 feet from center of middle stump. One of these lines is for a right-handed batsman and the other for a left-handed batsman.
- 2.8 The boundary must be clearly marked by cones/ground paint so that it is easily visible to the Umpires standing at the wicket.
- 2.9 CCL will provide match balls for every game to all captains before start of games.
- 2.10 In the event when CCL Home ground cannot be used then CCL will reserve another field to play the matches. In that case following dimensions should be used. Taking Rossmoor Park, Rancho Cordova as a reference.
- 2.11 Picture in [**Appendix-A**] shows rough idea about where pitch and boundaries should be set. This is to confirm all teams play in similar conditions.

## 3 Results

- 3.1 Winner gets 10 points.
- 3.2 Loser gets 0 points.
- 3.3 No bonus points will be awarded.
- 3.4 Washed out/abandoned before the 10<sup>th</sup> over of second innings is complete – By default Teams will split 5 points each with no change in Net run rate. Committee would try to reschedule washed out matches. If no game is possible before the end of the round, points would be split.
  - 3.4.1 Teams are also allowed to pick an alternate ground and play their abandoned game at a different venue if both teams are in agreement. All CCL rules would be followed in this scenario and the result of this game would be considered official at this point.
- 3.5 Teams carry forward their points/NRR earned against other in their group qualifying in the same division. Penalty points are **NOT** carry forwarded.
- 3.6 In the event of Tied game, “super over” shall break the tie. Super over rules are same as International T20.
  - 3.6.1 For Super Over, Both Captains need to nominate 3 batsmen and 1 bowler. These names shall be given to umpires in writing before start of super over.
  - 3.6.2 The team batting second in the match will bat first in the Super Over.
  - 3.6.3 Same ball (or similar age) as used at the end of each team’s innings shall be used for each team’s Super Over.
  - 3.6.4 The loss of two wickets in the Super Over ends the team's Super Over innings
  - 3.6.5 In case a tie is not broken at the end of a super over, subsequent super overs shall be played until the tie is finally broken.
- 3.7 Net Run Rate A team’s net run rate is calculated by deducting from the average runs per over scored by that team throughout the competition, the average runs per over scored against that team throughout the competition. In the event of a team being all out in less than its full quota of overs, the calculation of its net run rate of both teams shall be based on the full quota of overs to which the batting team would have been entitled and not on the number of overs in which the team was dismissed. Only those matches where results are achieved will count for the purpose of net run rate calculations. Reference Link ([ICC Rule](#))
  - If team get all out, scores will be divided by full quota of overs (20)
  - NRR will be considered up to 3 decimal places (xx.yyy) as available in Cricclubs

- 3.8 All teams MUST play their games on scheduled date/time/ground. Rescheduling can be accommodated only if there are available spots which are filled on first come first serve basis by CCL committee. Teams need to finish their game within that particular weekend. Teams changing time slot within the particular weekend must get approval from CCL.
- 3.9 Swapping is allowed as long as all teams agree. Umpiring assignments do not change in this case. Swapping must be approved by CCL.
- 3.10 Umpiring assignments do not change in any circumstances.
- 3.11 Forfeit: Failure to meet cut-off time will be considered as On Ground Forfeit and will be given penalty points (Section 13). There will be a fine of \$50 for every game forfeited by a team.
- 3.12 Walkover: In case opposition team does not agree to reschedule, game will be considered as giving Walk-Over (no penalty but 0 pts for loss). Deadline for conceding a walkover is Thursday 11:59pm. Team rep is responsible to communicate the walkover to opposing captain, umpires and the committee through email before the above deadline.
- 3.13 Failure to reschedule: If both teams agree on rescheduling, they own responsibility for finishing their game within that weekend when their game is scheduled originally. If teams cannot finish their rescheduled game within CCL deadline, both teams will get 0pts (no penalty points). CCL committee won't be watching over the fixture once it's deviated from original fixture.
- 3.13.1 Rain or ground issue & match didn't take place before deadline – 5 pts each
- 3.13.2 Rescheduled match for any other reason & match didn't take place before deadline – 0 pts each

## 4 Match Regulations - Basic Rules

- 4.1 A match shall be of one innings of each side. Each innings will be of 20 overs max. (updated from 18 overs to 20 overs in 2020)
- 4.2 LEVEL 5 Soft-T (Wilson) softball will be used which will be provided by CCL.
- 4.2.1 CCL committee purchases the ball from the same manufacturer and same Code for the entire season. There could be variations in the ball like hardness or ball not lasting the entire innings, CCL committee cannot control this. This can also not be used as a reason to reschedule a game. If the ball does not last an entire innings, CCL committee recommends using a new ball and umpiring team keep this consistent for both teams' innings.
- 4.3 Each bowler can bowl maximum of 4 overs. If there is a reduction in the number of overs before the match has started the maximum number of overs bowled by all 5 bowlers will be calculated by dividing the total number of overs to be bowled per innings by 5 and rounded up to the nearest whole number. Even in case of reduced overs 5 bowlers have to be used.
- E.g.: Match is reduced to 12 overs per side. Max each bowler can bowl is  $12/5 = 2.4$  (rounded to 3). 2 bowlers can bowl max of 3 overs and 3 bowlers can bowl a max of 2 overs.
- 4.4 All international cricket rules will be applied where not called out, except LBW and Leg Byes:
- 4.4.1 No LBW but if pads are used, we will have rule of 2-LBW-out. We understand pads could be for batsman's safety but it gives him unfair advantage over majority of others who don't use them and to still allow pads and make it fair to opposition team, we have 2-LBW-out rule. Above rule does not apply to helmets used for safety purpose.
- 4.4.2 No leg bye runs. This also means a player can't be given run-out in such case. Batsman still could be stumped as long as it is done while ball in play.
- *Body First -> Bat next: Can get out anyways except run outs. No runs.*  
If ball hits player's BODY first then consequently hits BAT without touching ground; and fair out scenario happens; player can be given out "Caught" or "Bowled" or "Stumped" but not "Runout".
  - *Bat First -> Body next: Ball is in Play*  
If ball hits player's BAT first then BODY, without touching ground; in a fair out scenario; player can be given out "Caught" or "Bowled" or "Stumped" or "Runout".



- *Body Only: Bowled or stumped out. No runs.*

If ball hits player's body then hits wickets before touching any of the fielders, batsman shall be given out "Bowled". Batsmen can also be stumped out in this case.

- 4.4.3 No crossing on dismissal- **New batsman coming in would have to take strike** unless a run out was affected at the non-striker end, or the dismissal happened on the last ball of the over (updated in 2023).
- 4.4.4 Run out at Non-Striker end – Batsmen can leave the crease **ONLY** after ball has left bowler's arm. He can be runout **ANYTIME** before that, regardless of bowling stride or action.
- 4.4.5 No run outs once umpire calls "over".
- 4.4.6 Player can be called out, if he is found outside crease while ball is in play and he fails to notify umpire that he is not attempting a run.
- 4.4.7 If stumps have bails, then at least one bail have to be dislodged to call OUT.
- 4.4.8 If stump has no bails, then ball hitting stumps is called OUT. Base of the spring-loaded stumps are considered part of the stumps. Note: Umpires and teams are advised not to keep bottles on or near the base of the stumps.
- 4.4.9 Full toss above the waist (Not Tshirt) is **NO ball** (consider batsman was standing upright at popping crease). Non full toss deliveries above shoulder is also a **NO ball**. No "one bouncer per over" rule.
- 4.4.10 Ball bouncing more than once before batsman is a **No ball** (updated in 2023).
- 4.4.11 If the ball pitches outside the pitch, it is considered a **No Ball** unless it has crossed the batsman below waist height and landed behind the striker's wickets. The slanted edges are also considered out of bounds of the pitch. (updated in 2023).
- 4.4.12 No Free hit for no balls
- 4.4.13 A **wide ball** shall be signaled if the ball is outside the reach of a batsman while in normal stance and playing a proper cricketing shot. If batsman moves closer to the wide marker (on the off side) before the ball is delivered and the ball goes beyond the wide marker and the batsman could have reached the ball with a proper cricketing shot, it is **NOT a WIDE**. The wide line marker moves (virtually) based on the batsman's position. However, this does not mean that a batsman can leave his stumps open and move towards the leg side to get a wide ball adjudicated for a ball which is inside the off side wide marker. In this situation the

off side wide marker should be used as a guideline. [For animated video click here.](#)

4.4.14 No under arm/throw bowling

4.4.15 For a delivery to be fair in respect of the feet, in the delivery stride

- The bowler's back foot must land within and not touching the return crease appertaining to his stated mode of delivery. Return crease should be 4.4 feet from middle wicket.
- The bowler's front foot must land with some part of the foot, whether grounded or raised behind popping crease.
- Both feet should be on the same side of the imaginary line joining the two middle stumps and behind the popping crease.

[For animated video click here.](#) (Note: CCL rule about the bowl pitching more than once before the wicket differs)

4.4.16 Fielding Team cannot have more than 5 players (excluding Wicket Keeper and bowler) fielding on ON (leg) side. There is no such restriction on OFF side.

4.4.17 Fielding Team must have at maximum 5 players (excluding Wicket Keeper and bowler) fielding in outfield. (We don't have 30 yard circle, but this should be judgment call by umpires).

4.5 There will be NO power play restriction on fielding side.

4.6 It is highly recommended to wear abdomen guard for all Cricket games at CCL

4.7 CCL will allow substitute runner for any player injured within the game. Both Umpires and opposition captain have to agree on this.

4.8 Each team must complete its bowling quota of maximum overs in 1 hour 40 minutes in 20 over game.

4.9 Intervals/Breaks

4.9.1 There shall be an interval of 10 minutes between each innings.

4.9.2 This interval would be reduced by the amount of time the first innings runs over (For e.g. 100 minutes is the allocated time for 20 overs. If the first innings takes

---

105 minutes, interval would be reduced to 5 minutes and 2<sup>nd</sup> innings starts on the same time to avoid delaying the next game.)

4.9.3 There shall be NO drinks break during each innings.

4.10 Since the number of overs are increased since 2020, there might be cases that the maximum time per innings would be shortened in order to complete required games in a day. Details would be communicated by the committee to all the teams.

4.11 If it rains during the game or have to leave ground and call the match off for any reason, both the captains and umpires are recommended immediately to call Nihar and/or committee. This is important to settle our ground booking for that day.

4.12 To avoid heavy wear and tear to playing conditions, shoes with spikes or studs are not allowed for either batsman.

4.13 Batsman can be "Retired Out" or "Retired Hurt". Umpires shall have final call on declaring Batsman "Retired Hurt".

4.13.1 Once Batsman is "Retired Out", he shall not come back to bat again in that inning.

4.13.2 If Batsman is "Retired Hurt", he may come back as soon as a wicket falls.

4.14 If player from fielding team leaves the field/or arrives late, he can only come back after completion of over and shall not be allowed to contribute with bowl/ bat for the same number of overs he was absent for. Moreover during batting he can bat either after being on the field for total number of overs he was absent for or after the fall of 5<sup>th</sup> wicket; whichever occurs first. (This rule will only be applicable for side bowling first (batting second))

Note: It is the fielding captain's responsibility to inform the umpire about player arriving late/ leaving the field of play or any substitution

Example1: If player arrives late at 3.4 overs. He can only join at end of 4<sup>th</sup> over and allowed to bowl 9<sup>th</sup> over onwards. (This rule will only be applicable for side bowling first (batting second))

Example2: If player arrives late after 12 overs. He can only join at end of 12<sup>th</sup> over and will not be allowed to bowl for the entire innings (of 20 overs). He can either bat after 4 overs of their batting innings (considering he has to be out for a combined 12 overs = 8 overs of bowling + 4 overs of batting) or after the fall of 5<sup>th</sup> wicket. (This rule will only be applicable for side bowling first (batting second))

## 5 Scoring

- 5.1 Cricclubs app should be the default method for scoring. Instructions for scoring using the app are located [here](#)
- 5.2 It is advised to continue with app scoring and parallelly use paper scoring in case of app, network issues. The app caches all the data locally and upsteams it from the phone to the web when it regains connectivity thus providing continued ball to ball scoring details.
- 5.3 Dot ball scoring is the norm for CCL matches. Dot ball scoring is defined as the recording of every ball received by each batsman, as well as every ball bowled by each bowler.
- 5.4 First and Last names of all players shall be recorded in the score sheets with the Captain (\*) and wicket-keeper (+) of each side identified.
- 5.5 Names of the Umpires and the team that won the toss.
- 5.6 Extras scored in each innings, separated by byes, wides and no balls
- 5.7 Fall of wickets and Over # for each wicket that falls and the batsman the got out.
- 5.8 The names of players effecting a dismissal shall be recorded. This includes players taking a catch or affecting a run out dismissal.
- 5.9 Bowling Analysis for each bowler, which shall include Overs, Maidens, Runs, Wickets, Wides and no balls.
- 5.10 Every team should be provided with the standard CCL score sheet prior to start of season. No other score sheet will be allowed. Teams need to print those along with umpires' score sheets.
- 5.11 Home team will be responsible for umpire score sheets.
- 5.12 The score sheet data for each game must be uploaded to CCL website by Thursday midnight of that week. If a team does not meet this deadline, they will be penalized with penalty points.
- 5.13 Each team is responsible for uploading the detail scoring information of their team's batting and bowling and final scores (including runs, number of overs and wickets) for each team. Do not upload opposition team's bowling/batting data. This is the minimum requirement for scoring uploads to be called complete by the deadline to avoid scorecard penalty.
- 5.14 If live scoring was not used, it is recommended that you update match summary with both teams' scores in match summary.
- 5.15 Any corrections to the scorecard or updating the Man of the Match should be made to the scorecard before 11:59pm of following Thursday after the game.
- 5.16 **No changes would be allowed after the Thursday deadline.**

## 6 Ethics and Expectations

It is the duty of every player to play the game in the highest tradition of sportsman spirit. Captain of the team is responsible for his players' behavior on and off the field of play. It is the duty of the captain of a team to resolve all problems on the field in an amicable manner. The umpires are required to have high moral grounds in doing their officiating duties. Personal prejudices or their own team benefits should never come into play in any their decisions. There needs to be a basic trust in the umpires and their decisions by both the teams on the field. Fielding teams should resist from excessive appealing and the batsmen should resist from trying to show up the umpire in case of a mistaken decision. Any complaints about anything must be lodged in writing within a week of occurrence (via Email to [ccl\\_committee@googlegroups.com](mailto:ccl_committee@googlegroups.com)) by the Captain to Executive Committee.

All team representatives are expected to seek committee permission before sending any non-CCL related communication to the board whatsapp or email group.

## 7 Teams

- 7.1 CCL 2024 has total of 28 teams. 21 teams are considered as “old- returning” teams.
- 7.2 New teams are defined as the team who has not played previous year of CCL season.
- 7.3 New teams in their first season are expected to pay a premium of additional \$200 on top of the registration fees.
- 7.4 Team Name change – “old” teams can change the name before the start of the season and will be still considered as a “old” team as long as they have atleast 7 same players who played from that team under old name in the previous season, still playing from their team under new name.
- 7.5 Team Split- The team that registers under a new name can still be considered an “old” team as long as the team has atleast 7 players who played for a single team in the previous edition of CCL. A team which gets formed by combining players from different teams in previous edition would be classified as a “new” team.
- 7.6 Starting 2022, if a new team has 7 players who have played in previous edition of CCL they would also be considered “old-returning” team and would not need to pay the additional \$200 premium charged for new teams.

## 8 Players

- 8.1 A match shall be played with a minimum of 7 players from each team.
- 8.2 Player must not in any case, comment/taunt on any player's caste, creed, color, nationality, religion or personal life.
- 8.3 A team can register a new player at any time but can only play from that particular team once played first game.
- 8.4 Active part in the game: Player must participate in atleast 25% of the completed fielding innings OR have bowled/ batted OR have sustained a physical injury during the game to be considered to have taken 'active part in the game'. It is the responsibility of the captain to inform the umpires about player arriving late/ leaving the field of play or any substitution that happen on the field.

The game counts towards the "Player qualification for playoffs" only if player has taken active part in the game. The opposition team or umpires have the right until the following Thursday 11:59pm deadline to report an infraction to committee. Committee/ DRC shall adjudicate the match qualification after consulting with both the team reps/ captains, umpires and other evidences if any. If a player is considered to not take active part in the game, the game shall be deducted from his played number of games. (Updated in 2023).

- 8.5 Player qualification for playoffs (Updated in 2024): A player has to play minimum of half - 50% of team's league games (**rounded down** to next whole number) to qualify for Play-off games. 2024 qualification number is "6 games" based on 13 min games before playoffs.

If a game has not commenced and has been called off due to weather or opposition team forfeit/ walkover and is unable to be completed before the round's deadline, thus not allowing the teams an opportunity to enter their playing 11, this game would not count towards the team's min number of games. For e.g: 1 wash out game and 1 forfeit by opposition would bring the min games for a team in 2024 down to 11, hence a player would need to play 5 games to qualify for playoffs ( $11/2 = 5.5$  rounded down to 5). In case a team is conceding a forfeit or walkover the min number of games for that team would remain unchanged.

Teams are recommended to publish their qualified players one day before match to allow opposition to verify minimum number of matches requirement stated here. If

team in playoff game has a player not qualifying this requirement, is subjected to forfeit that game. Opposition captain has right to verify this requirement at any time before or after game is finished.

- 8.6 Player can't switch team after playing 1st match. If his team is out of CCL for any reason, he will have to wait for next season to be able to take part in CCL again.
- 8.7 Captains must enforce discipline within the Team and avoid player confronting with opposition team player.
- 8.8 Strictly no comments or taunting on caste, nationality, religion or personal abuse. Any violation on such things should be immediately reported to CCL committee and CCL Board, and CCL has full rights to ban such player from playing in league if found guilty.
- 8.9 Uniform requirement: All players must be in colored uniforms. Players cannot wear white colored jerseys. Starting April 1st 2024, **maximum of 2 players shall be permitted to participate in the game without a matching team jersey** (t-shirt). Failure to comply with this requirement would result in players under infraction not being permitted to take part in the game. Umpires are expected to enforce Uniform requirement and is not at the discretion of opposition captain.



---

## 9 Players' Code of Conduct

The under mentioned Player's Code of Conduct is a reminder to players that Cricket is a game which has a rich tradition of sportsmanship behind it. Those who take part in the game are expected to uphold this tradition and the spirit of the game.

DRC would be responsible to determine the level of infraction and enforce the Code of Conduct and adjudicate appropriate penalties incase any players are found violating below rules.

- 9.1 The captains are responsible at all times for ensuring that play is conducted within the spirit of the game as well as within the CCL rules and regulations.
- 9.2 Players shall not at any time engage in conduct that could bring them or the game into disrepute.
- 9.3 Players shall not use foul words to or physically confront with opposition team player or umpires.
- 9.4 Players must at all times accept the Umpire's decision.
- 9.5 Players must not show dissent at the Umpire's decision
- 9.6 Players shall not use crude or abusive language (known as "sledging") nor make offensive gestures.
- 9.7 Players shall not AT ANY TIME engage in conduct that may jeopardize use of the ground.
- 9.8 Players/Spectators **must NOT smoke or consume any alcoholic beverages** on the ground, in the parking lot or in the school premises.
- 9.9 **Loitering/ urination on the ground is strictly prohibited.** Players must use the designated portable restrooms.
- 9.10 Players or team representatives are expected to raise any issues or concerns addressed to CCL committee by sending an email to 'ccl\_committee@googlegroups.com' and **only including your own team reps or parties involved.** Individuals shall be respectful while raising any concerns. The board email group or whatsapp group with all team reps shall not be used as an avenue for this purpose.

---

## 10 Application and Enforcement of the Code:

- 10.1 The Code of Conduct will serve as a guide to the Rules/CCL Committee in dealing with the infractions.
- 10.2 The Code of Conduct is applicable to all the games played within CCL.
- 10.3 Every Captain/Representative is required to have this document acknowledged to every team member. Lack of knowledge of the existence of this document does not constitute as an excuse for non-compliance.
- 10.4 DRC would be responsible to determine the level of infraction and enforce the Code of Conduct and recommend appropriate penalties to CCL committee in case any players are found violating Player Code of Conduct.
- 10.5 CCL committee and/or disciplinary committee has all rights to impose appropriate probation/penalty to any player playing in CCL, once found guilty. The probation/penalty will be applied by CCL in accordance with the code of conduct for players and player support personnel document released by the International Cricket Council effective 22<sup>nd</sup> September 2016 [Link](#). Any monetary fines mentioned in the document could translate into probation/penalty as applicable decided by CCL.

---

## 11 Umpires

- 11.1 Every team needs to send neutral umpires as per schedule. Captain of particular teams will be responsible for not sending umpires and subjected to penalty (12.1). There will be a fine of \$50 if both umpires are a no-show. All teams should be encouraged to send their best available players for umpiring to overcome umpiring inconsistency.
- 11.2 Umpires are recommended to be on ground 15 minutes earlier. Umpires should toss no later than 5 minutes before match start time & clarify boundaries with Captains.
- 11.3 Umpires should penalize a team for late start:
  - 11.3.1 One team is late: If one team does not have 7 players at game start time and is not ready to field a team OR the home team hasn't setup the ground, umpire must penalize the responsible team- 1 over for every 5 minutes.
  - 11.3.2 Both teams are late OR game delayed by external factors: If both teams are late (do not have 7 players) OR if the previous game runs over time OR if game start time is delayed by rain or wet outfield conditions, umpire must reduce equal number of overs from either team- 1 over EACH per team for every 10 minutes. In case of a delayed previous game, toss must be done outside the field before previous game ends.
  - 11.3.3 Umpire show up late: If umpires show up after the scheduled start time, either playing team has to report the infraction to committee right away. Applicable penalty would be assessed to the umpiring team. Teams should start the game right away with the batting team umpires OR any other neutral umpires if available from previous game. If the game is delayed by more than 10 minutes, 1 over must be deducted from EACH team's quota of overs.
- 11.4 Umpire should monitor discipline throughout the game. Foul words, bad behavior should be reported to CCL committee. Umpires should give 1<sup>st</sup> warning to player and Captain of his team. 2<sup>nd</sup> warning to Captain of his team, and if same offence repeats, umpires have full rights to disqualify that player immediately from that game.
- 11.5 If umpires are splitting main umpiring and leg umpiring duties, umpires shall follow a consistent split across both the innings. E.g: One umpire officiating first innings as

---

main umpire and the other umpire officiating second innings as main umpire is not a recommended practice.

11.6 In the event of one or more neutral umpires not being available or present:

11.6.1 Both teams' captains have to report that to CCL committee and Board using an email group and request for volunteers. If no one volunteers within the acceptable time to finish the game before the start of next game then follow below.

11.6.2 The Captain of the batting side can assign players in his side as umpires. It is urged that the interchanging of umpires in such a case be kept to a minimum. Umpires from both sides, need to be nominated before toss.

11.6.3 If a Captain has an objection to one or more members of the opposing side acting as an umpire, he needs to inform the opposing Captain about this before the toss for innings.

11.7 Umpires should collect playing XI and substitute names from both the team before toss. Players only in the list can play the game.

11.8 Leg umpires should stand in the line of stumps. Leg umpires has important jobs like monitoring height no ball, dead ball, short run, runouts, stumping etc.

11.9 They should use umpire scoresheets to score. Scoresheets are made to make sure umpires are able to collect required information with least distraction.

11.10 Home team is responsible to provide umpiring score sheet to the umpires and umpires are responsible to keep track of scoring during the game. Umpires have to sign the Final score sheet at end of the game.

11.11 Umpire's decision will be FINAL. They are advised to take their time and consult the other umpire if needed before making the decision. It is very important that umpires apply basic cricket rules + CCL rules before making decisions.

11.11.1 If Umpire is in doubt? Umpires are the FINAL decision maker for any occurrence during CCL match and it's recommended that they follow below guideline when in doubt.

- First consult with other umpire
- If needed consult the rules by calling your teams captains or CCL committee members.
- Feel free to revert your decision.
- Decision will not be reverted after the next ball is bowled or the game is complete.

11.12 Use of live streaming is purely for viewership. Umpires shall not use any technology or replays from live streaming to make an on field decision.

11.13 Umpires will identify Man of the Match for each game based on game data.

---

## 12 Delays or Interruptions

### INTERRUPTED MATCHES DUE TO WEATHER OR LIGHT CONDITIONS OR OTHER UNFORSEEN CONDITIONS

12.1 If a start of the game is delayed, the game must be reduced according to rule 13.2 (Late Start clause) in the Penalty section.

12.1.1 If a game start is delayed, a game must comprise of a minimum of 5 overs a side. At least 5 bowlers have to be used. In the instance of a 5 over a side game one bowler cannot bowl more than 1 over.

12.2 If a delayed game starts off with more than 10 overs a side, in case of an interruption after the 10<sup>th</sup> over of 2<sup>nd</sup> innings, result of game will be decided with the help of Duckworth Lewis calculators available online: <https://www.easycalculation.com/sports/duckworth-lewis-calculator.php>

Please only use above calculator for consistency.

12.3 Any game interrupted before the completion of 10<sup>th</sup> over of 2<sup>nd</sup> innings, shall be re-played from the start. These games shall be rescheduled by CCL only if open slots are available else points would be shared as described in Section 3 (Results).

12.4 If a match cannot complete on time and is blocking the start of the next game in schedule:

12.4.1 If 19<sup>th</sup> over of the 2<sup>nd</sup> innings hasn't started, the match should be halted by start time of next match and result decided based on the duckworth-lewis-calculator above. Umpiring teams need to enforce this.

12.4.2 If 19<sup>th</sup> or 20<sup>th</sup> over of the 2<sup>nd</sup> innings is in progress, the match should continue and can use a maximum of 15 minutes to finish their allotted overs. The following game should start with reduction of overs according to rule 13.2.

12.4.3 The only exception to the 15-minute grace period is in-case the game ends in a tie and the result needs to be determined by a super over. In this case, the next game would have to wait for the super over to complete and the over reduction rule (13.2) would apply for the following game.

12.5 Committee cannot control the weather conditions and reasons such as dew on the pitch/ground are not reasons to be used to start a game late.

---

## 13Penalty

### 13.1 Umpires late/No show

13.1.1 For one umpire showing up late (past Game start time), it will be -2 penalty points.

13.1.2 For both umpires showing up late (past Game start time), it will be -4 penalty points.

13.1.3 For one umpire not showing up for the game, it will be -5 penalty points.

13.1.4 For both umpires not showing up for the game, it will be -10 penalty points and a fine of \$50 paid to ccl committee.

### 13.2 Late Start

13.2.1 One team is late: If one team does not have 7 players at game start time and is not ready to field a team OR the home team hasn't setup the ground, umpire must penalize the responsible team- 1 over for every 5 minutes.

13.2.2 Both teams are late OR game delayed by external factors: If both teams are late (do not have 7 players) OR if the previous game runs over time OR if game start time is delayed by rain or wet outfield conditions, umpire must reduce equal number of overs from either team- 1 over EACH per team for every 10 minutes. In case of a delayed previous game, toss must be done outside the field before previous game ends. Both teams will get 5 minutes to start the game after the previous game ends.

13.2.3 Umpire show up late: If umpires show up after the scheduled start time, either playing team has to report the infraction to committee right away. Applicable penalty would be assessed to the umpiring team. Teams should start the game right away with the batting team umpires OR any other neutral umpires if available from previous game. If the game is delayed by more than 10 minutes, 1 over must be deducted from EACH team's quota of overs.

13.3 Failure of a team starting a game, with minimum of 7 players: Umpires shall cut 1 over for every 5 minutes from that team's batting inning.

13.3.1 In case where ground is still utilized by earlier CCL game, Time starts, 10 minutes after first game is finished. Home team will get 10 minutes to setup ground. In such cases toss must be done outside ground when possible.

13.4 Forfeit without notifying opposition team, umpiring team and CCL committee, before deadline: -5 penalty points and fine of \$50 paid to ccl committee.

13.5 Failure to upload scores by Thursday 11:59pm or incomplete scorecard: -2 penalty points

13.6 If a player is reported practicing on the CCL ground without reservation, he would be considered to be violating the CCL by-laws. If Dispute Resolution Committee has evidence to prove the violation, they would sanction the player (all players involved) a

ban of 3 games. This player would serve this ban for the next 3 games that their team participates in. If this violation happens near the end/ before the start of the season, the ban would carry forward to the next season until it is served in entirety.

- 13.7 Penalty points are NOT carry- forwarded to subsequent rounds. Once qualification for the round is determined (Round 1 to Round 2, or Round 2 to Knockouts) the penalty points from previous rounds are reset.
- 13.8 If a team incurs a penalty during playoffs, the penalty shall carry forward to the subsequent year. Team captain shall ensure all the team duties such as umpiring assignments are fulfilled even after the team gets knocked out of the tournament.
- 13.9 Mandatory attendance for reps meeting: Each team is responsible for sending at least 1 representative to the season opening reps meeting to ensure proper communication and voting on new proposals. Failure to comply to this would result in -5 penalty points and fine of \$50 paid to ccl committee. The team shall start the tournament at -5 points. (Update in 2023- to be followed from 2024)

## 14 Awards

CCL believes in recognizing players and teams for their good performances with awards after every tournament. CCL follows the CricClubs website rankings to decide on the awardees for the series.

- 14.1 No one player will get more than one Individual award. This is to encourage more number of different individual getting awards. Player who is eligible for more than one award will only receive an award for the highest of the sub-category he is eligible for. (Player of the Playoffs award might be an exception here)
- 14.2 Players stats accounted in the Division B games (if any) will also be considered towards awards.
- 14.3 For the Best Ranked Player, Batting and Bowling individual awards stats will be considered till the end of the tournament (including playoffs).
- 14.4 [Here is the link for player rankings](#). Best ranked players are sorted by total points, and best batsman and best bowlers are sorted by points in their respective categories.
- 14.5 CCL has classified awards into two categories with multiple subcategory within it i.e. Team awards and Individual awards:

Detail listing with number of the awards (total 64 + ~10-15) for both the category are:

### **Team Awards: (Total 33)**

1. CCL winners:
  - a. Winner trophy for "CCL <year> Champions" (1)
  - b. Individual Gold Medals to each members of the team. (15)
2. CCL runners up:
  - a. Individual Silver Medals to each members of the team (15)
3. Trophy for "CCL <year> Best Team" (1)

This award goes to the team who ends at the top of the table before the playoffs.

4. Trophy for "CCL <year> Division B winners" (1)

### **Individual Awards: (Total 31 + ~10-15)**

1. Man of the series "CCL <year> Man of the Series"- Based on best ranked player of the series (1)
2. Best Ranked Player Awards:
  - a. Top ranked players will get an award. (~9)



3. Batsman Award:

- a. One "CCL <year> Best Batsman" (1)
- b. Top batsmen will get an award. (~9)

4. Bowler Award:

- a. One "CCL <year> Best Bowler" (1)
- b. Top bowlers will get an award. (~9)

5. Player off the playoffs (1)

6. Special Achievement awards: (~10-15)

Individuals who have achieved special performances will also be awarded. Special achievements are: 5 wicket haul in a match, 50+ runs in a match, hat-trick, etc.

\*Note: Categories/ number of awardees are subject to change by CCL committee

# 15Appendix-A

Pitch and Ground dimensions: All Dimensions are not to scale.

## Pitch Dimensions:

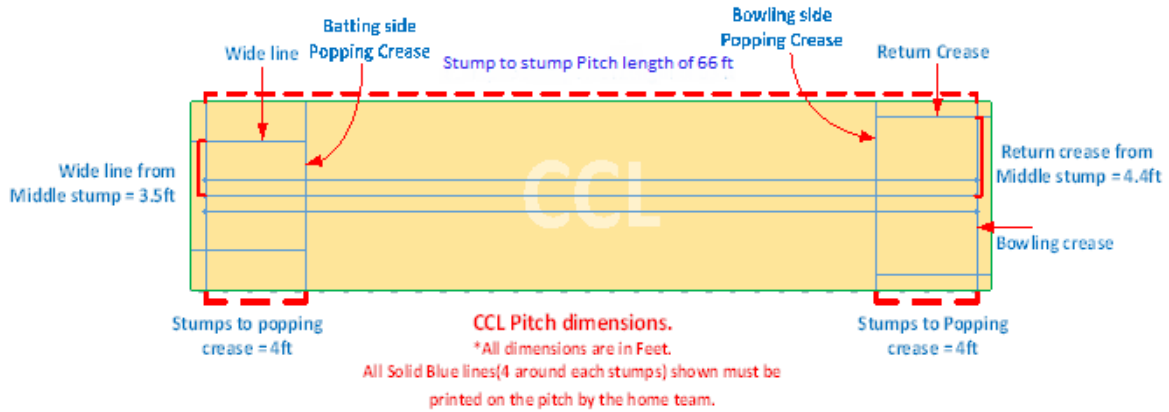

## 360 Ground Requirements:

Circle with 180Ft Diameter from center of the pitch.

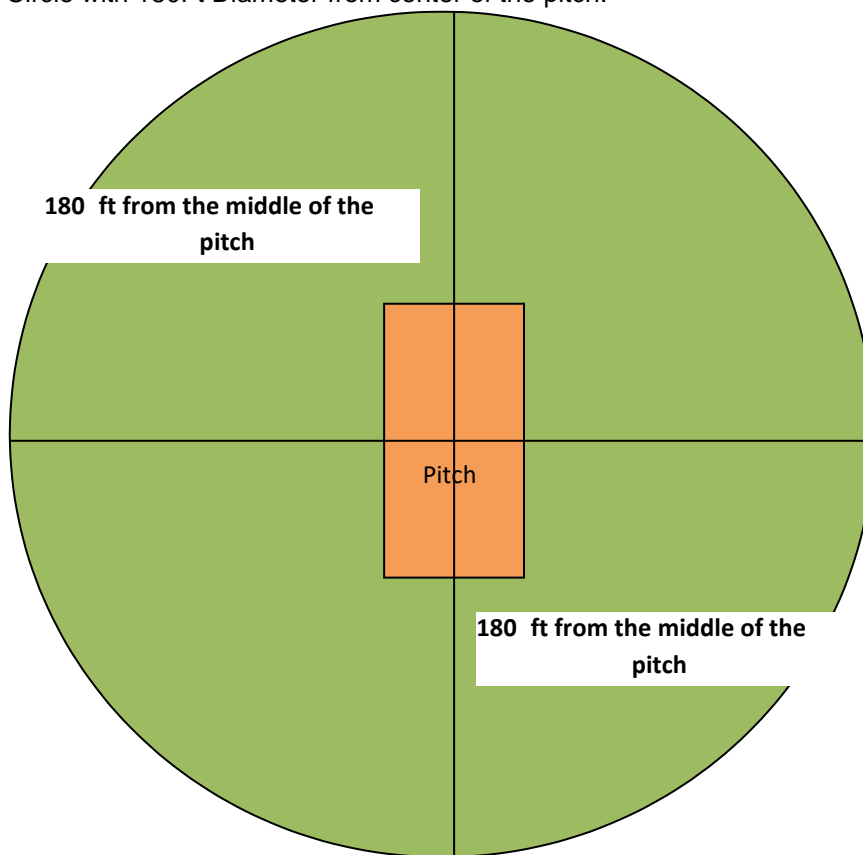

**Update 2019-** In order to restore the balance of bat and ball and compensate for the hardness of the ball, the boundary dimension has been increased to **180ft**.

## 16Appendix-B

**Team Representatives is available on the ccl website with login to maintain privacy of the information.**

*Any other general questions or request: Do not misuse PDL with emails addresses of all captains and representatives; only include CCL committee members. Committee members will discuss and decide on such matters. Again, CCL committee will use 3-2 majority where ever applies.*